



## On exergy and sustainable development—Part 2: Indicators and methods

Mei Gong<sup>a</sup>, Göran Wall<sup>b\*</sup>

<sup>a</sup> Department of Mechanical Engineering, Division of Energy Systems, Linköping University, SE-581 83 Linköping, Sweden

<sup>b</sup> Independent Researcher, Solhemsgatan 46, SE-431 44 Mölndal, Sweden

(Received 20 November 2000, accepted 14 February 2001)

**Abstract**—This second part is the continuation of Wall and Gong [Exergy Internat. J. 1 (3) (2001), in press]. This part is an overview of a number of different methods based on concepts presented in the first part and applies these to real systems. A number of ecological indicators will be presented and the concept of sustainable development will be further clarified. The method of Life Cycle Exergy Analysis will be presented. Exergy will be applied to emissions into the environment by case studies in order to describe and evaluate its values and limitation as an ecological indicator. Exergy is concluded to be a suitable ecological indicator and future research in this area is strongly recommended. © 2001 Éditions scientifiques et médicales Elsevier SAS

### Nomenclature

$E_{\text{indirect}}$	exergy indirect input . . . . .	J
$E_{\text{in}}$	exergy input . . . . .	J
$\dot{E}_{\text{in}}$	exergy power of input . . . . .	W
$E_{\text{out}}$	exergy output . . . . .	J
$E_{\text{net,pr}}$	exergy net product . . . . .	J
$E_{\text{pr}}$	exergy of product . . . . .	J
$\dot{E}_{\text{pr}}$	exergy power of product . . . . .	W
$E_{\text{waste}}$	exergy of waste . . . . .	J
$t$	time . . . . .	s
$t_0$	time when a project starts, e.g., the first steps to build a power plant . . . . .	s
$t_{\text{close}}$	time when an operation, e.g., a power plant closes . . . . .	s
$t_{\text{life}}$	time when a project finally closes, i.e., after complete restoration to original state . . . . .	s
$t_{\text{pay back}}$	time when a pay back situation is reached . . . . .	s
$t_{\text{start}}$	time when an operation starts . . . . .	s

### 1. INTRODUCTION

Most of the present activities in modern industrialized societies or products on the market do not belong to an ecologically sustainable society. This is a problem, since it also interferes with powerful economic interests. There is an obvious danger and temptation that scientists may prefer to please these interests than point out ecologically unacceptable activities. Prof. Mustafa Tolba makes the situation clear: “Sustainable development is not a slogan, but rather an exacting and demanding process. Meaningful reforms and bold policies are needed. Perception must be transformed, beginning with how we rate the environment” [2]. So far sustainable development mainly involves addressing some general principles or establishing often costly certificates, e.g., ISO 14000, or “green labels” to put on products, whereas legal means or effective concepts and methods are absent. Too much of environmental work is dedicated to greenwash and massive propaganda to give people a false sense that the situation is improving. This only makes the situation worse. By adopting exergy based tools and methods we will initiate “an exacting and demanding process” that Tolba is asking for and our perception will be transformed. Exergy gives a consistent physical value to energy and material resources with respect to the environment that becomes an important supplement to monetary values. By

\* Correspondence and reprints. Web page: <http://exergy.se/>  
E-mail address: gw@exergy.se (G. Wall).

this, “how we rate the environment” will change. However, this often gives an unpleasant insight to the resource use in terms of poor exergy efficiencies. In spite of this, it is our hope that this paper will promote the use of exergy and a development towards sustainable resource use patterns.

In the first part of this paper [1] we outlined the conditions and concepts associated with the use of exergy as an ecological indicator. In relation to this we should notice that while we must determine which indicators appear most appropriate, the ultimate value of these indicators in the long run is determined by nature. One direct conclusion of this fact is the precautionary principle, i.e., to be on the safe side. A reference to the beliefs of so-called primitive people that live in harmony with nature is recommended [3, 4]. The purpose of Part 1 [1] was to introduce the exergy concept and to give a foundation for the methods that will be introduced in this part, together with a number of different ecological indicators and arguments in favor of using exergy as an ecological indicator.

Every real process is irreversible, i.e., it always implies exergy destruction and usually also exergy losses as waste flows to the environment. Exergy loss is defined as the exergy input minus the exergy output, i.e., exergy destruction and exergy waste. Exergy is an extensive quantity, with the same unit as energy. All materials have a definable and calculable exergy-content, with respect to any defined external environment. The exergy content of a natural resource input to the economy can be interpreted as one general measure of its potential “usefulness”. An exergy rich metal ore is more valuable and useful than the surrounding bedrock. Sometimes this usefulness can lead to harmful consequences. The exergy content of a waste residual, for example, may generate harm by driving uncontrolled reactions in the environment. Thus, exergy embodied in wastes would be one measure of the potential for causing harm to the environment. The embodied exergy in wastes can also drive physical processes, e.g., climate warming and chemical reactions like ozone depletion. Exergy content is probably correlated more closely with environmental damage than simple mass. Exergy’s association with value and harmfulness suggests that exergy may have much promise as an ecological indicator.

Exergy is a physical concept that quantifies the usefulness or value of energy, material and information in a measure that is both descriptive and useful [5, 6]. So far, it is mainly used as a complement to the energy concept, to describe, analyze and improve energy systems and processes. However, it is a much more useful con-

cept, and could be applied across the breadth of ecosystem and industrial application.

Exergy is lost in all processes, mostly—but not entirely—as low temperature heat. Locally waste heat may create severe damage, but on a global scale this is so far no problem. The influence of waste heat on the environment is well described by exergy. A higher exergy content of heat means a higher temperature difference with the environment, which will result in a greater impact.

Besides heat there are also often substances that contain “unexpended” exergy that do not belong to the environment. These waste materials still have potential to drive processes. Especially, if these waste materials contain unfamiliar or harmful chemical substances in delicately balanced biological cycles that can cause harmful effects, e.g., DDT, heavy metals and PCB. Very small amounts of toxic chemicals are often enough to destroy life processes. These waste materials drive the environment away from ecological equilibrium. For this reason, “unfamiliar” exergy can be regarded as a potential for causing environmental harm. We also have the problem of nourishing the environment in a harmful way, i.e., new micro-organisms and diseases may appear, as we explained in Part 1 of this paper [1].

Ecological or environmental indicators are increasingly seen today as necessary tools for sustainable development. By the increasing lack of resources and the destruction of our environment this is becoming more important year by year. Today, methods like Life Cycle Analysis or Life Cycle Assessment (LCA) have become popular since they indicate the sources of the environmental problems in the production processes. Unfortunately, these are also methods that allow a high level of manipulation when it comes to evaluating the total assessment by using different weight factors. The method of Energy Analysis, firstly developed in mid-seventies, may be regarded as a pioneering attempt to relate environmental effects from the energy use to its sources [7]. Many of the people working in this field were at this time driven by a strong concern for the environment [8]. There were also early attempts to develop Energy Analysis to include the exergy concept, i.e., Exergy Analysis, as well as the total resource use [5, 9]. However, the cause and effect relations are usually not so easy to analyze, as described in Part 1 [1]. A serious problem with LCA is how to evaluate the different emissions with regard to environmental effects. This will be discussed, together with a short presentation of the LCA and the Exergetic Life Cycle Analysis (ELCA) [10]. Also the Life Cycle Exergy Analysis (LCEA) will be presented [11], which combines LCA with the exergy concept and

distinguishes between renewable and non-renewable resources.

Besides developing concepts and methods to better incorporate environmental conditions into engineering design we must also increase our knowledge in this area and begin to experiment with new forms of analysis and exergy conserving technologies as well as renewable resources. Two recently launched projects are examples of important attempts to meet these demands, the Encyclopedia of Life Support System (EOLSS) [12] and the concept of Ecotechnology at Japan National Institute for Resources and Environment (NIRE) [13]. The concept of Industrial Ecology is also promising and Connelly [14] has introduced indicators related to exergy, however, this must be made more explicit.

By the EOLSS a unique and challenging new approach to knowledge is offered. Relevant knowledge will be collected and exposed in order to establish a *living body of knowledge* on life support systems. Knowledge will develop by the use of the internet and a global concern. It may in the future, with even better communication technology, lead into the development of an open global intelligent system dedicated to sustainability, equity and peace. With the EOLSS the lack of knowledge about life support systems will also be made more clear, and hopefully these current knowledge gaps will gradually shrink. The knowledge of many indigenous people, who are mostly truly ecologically sustainable, will also be presented in the EOLSS, which will make it a unique source of knowledge.

In order to meet these demands of a sustainable development, NIRE has proposed the novel scientific and technological concept of ecotechnology [13]. This idea unifies technology with ecology, with the latter being based on mutualism recycling/regeneration in a broad sense. The role of NIRE is to conduct fundamental research toward the development of ecotechnology, which is classified into:

- (1) Minimum Environmental Impact (MEI) and Maximum Energy and Resources Utilization (MERU) technologies,
- (2) environmental behavior of offensive substances, and
- (3) evaluation of environmental, energy and societal safety.

MEI technologies include generic processes that emit less pollutants, recover and detoxify pollutants, and remediate the polluted environment. MERU technologies are related to energy and resources conservation, and the development of renewable resources. The second category is exemplified by source inventories of environmentally of-

fensive substances, and the elucidation and modeling of their behavior with respect to transportation and transformation in the environment. The third category relates to the construction of a system for the evaluation of environmental impacts, energy usage, chemical materials safety, and the hazards to society. In pursuit of human progress through advances in science and technology, NIRE has contributed to energy and resources development, and environmental protection. In view of creation of Ecotechnology to ensure sustainable development, NIRE will endeavor to make further progress in research and development to unify industrial technologies with environmental technologies.

By more and more obvious reasons the present use of science and technology lacks ability to meet the increasing environmental crisis. Despite the fact that science and technology continue to make dramatic leaps the environmental situation becomes worse. The fascination with Moonwalks made us blind for what was happening in our backyard. The development of science and technology walked hand in hand with resource depletion and environmental destruction. Similarly, we must now walk away from these problems, which implies a new approach and paradigm. This is why we see an increasing need for projects as EOLSS, ecotechnology, the exergy concept and the ideas presented in this paper. Also, as stated above, the approach to sustainable development is delayed from too much emphasis on environmental reporting, e.g., lists of non-comparable emission or of percentage reductions in “emissions” or “wastes” with reference to prior years. Too many activities are also just lip service and greenwashing, which is often supported by environmental labels, certificates and awards. The use of a clear definition of sustainable, and a common unambiguous measure like exergy in combination with exergy flow diagrams exhibiting both inputs and outputs, would constitute a major step forward over current practices.

We will close the introduction by again quoting Tolba [2]: “. . . poverty, disease, skyrocketing populations, accelerating natural resources destruction and mounting ecological degradation are our problems, affecting each and every one of us. In this, there is no us and them. We are all in it together”.

## 2. ECOLOGICAL INDICATORS

There are a number of definitions of ecological or environmental indicators in the literature. Most of these are related to the concept of sustainability, which will be further discussed below. The purpose for most indicators

is to indicate whether a development is towards or away from sustainability.

An ecological indicator should be easy to understand and an unambiguous quantity. Within the Organization for Economic Co-operation and Development (OECD) the following definition is used: an indicator is “a parameter, or a value derived from parameters, which points to, provides information about, describes the state of a phenomenon/environment/area, with a significance extending beyond that directly associated with a parameter value” [15].

Indicators are bits of information that should reflect the status of large systems. They should be a way of seeing the “big picture” by looking at a smaller piece of it. They should tell us which direction a system is going: up or down; forward or backward; getting better or worse or staying the same [16]. Let us also look closer to the concept of sustainable development.

In the World Conservation Strategy by International Union for Conservation of Nature and Natural Resources (IUCN), United Nations Environment Program (UNEP), and World Wildlife Foundation (WWF) the word sustainable development was first introduced [17]. In the Brundtland Commission in 1987, The World Commission of Environment and Development (WCED), sustainable development was defined as “. . . development that meets the needs of the present without compromising the ability of future generations to meet their own needs” [18].

The concept has been widely spread, and there are many other definitions and interpretations of the concept of sustainable development and sustainability, e.g., so called socio-ecological principles have been introduced as criteria for sustainability in order to make the concept more operational. The four principles are [19]:

- (1) Substances extracted from the lithosphere must not systematically accumulate in the ecosphere.
- (2) Society-produced substances must not systematically accumulate in the ecosphere.
- (3) The physical conditions for production and diversity within the ecosphere must not systematically be deteriorated.
- (4) The use of resources must be efficient and just with respect to meeting human needs.

These principles are successfully marketed by the Natural step organization [20]. However, there is an obvious risk with an interpretation of these principles that preferentially favors the market mechanisms rather than the environmental conditions. Often environmental improvements are judged with reference to other products

or production processes instead of the conditions of the environment in order to justify environmentally harmful activities. ISO certification, “green labels” on products and “green awards” often becomes more important to the market than the environmental concern, i.e., greenwash. Therefore, some authors also point out the importance of ethics and morals to the question of sustainability or vitality in the society [21–23]. “The present trend of resource depletion and environmental destruction is related to a lack of morals in society” [24].

Delin [25] has proposed “thermodynamic conditions of a sustainable life-support system”. From *figures 7 and 8* in Part 1 [1] of this paper we see that the earth receives solar energy and emits heat radiation. The incoming energy has a high exergy, i.e., about 93% [1], whereas the outgoing energy has no exergy at all, relative to the earth. This change of exergy is the driving force on the earth, as earlier mentioned. There is a slight imbalance between the incoming energy to the earth and the outgoing energy from the earth. Beside the geothermal energy flow, this difference is due to the human extraction of deposits, i.e., stored energy as fossil and nuclear fuels, see *figures 1, 11 and 12* of Part 1 [1]. From Delin’s definition of a “sustainable life-support system” the incoming energy must be higher than the outgoing energy, excluding the geothermal energy, i.e., exergy must be stored as deposits on the earth. However, if the incoming energy is less than the outgoing energy, then exergy from deposits are depleted, and the system is not sustainable. The definition of Delin can be related to exergy stored on earth, or the change of exergy stored on earth as a measure of the value of the ecological system as described by Jørgensen [26].

We will now look at some definitions of ecological indicators from the literature. Most of these definitions also exemplify the close linkage to the concept of sustainability, as been addressed above.

By the use of organisms as an ecological indicator the following definition is often applied: an ecological indicator is an individual species or a defined assemblage of organisms that serves as a gauge of the condition of the environment. The term is a collective term for response, exposure, habitat, and stress indicators [27].

The National Center for Environmental Research and Quality Assurance (NCERQA) uses the following definition: an ecological indicator is a characteristic that is related to, or derived from, a measure of a biotic or abiotic variable that can provide quantitative information on ecological structure and function [28]. An indicator should thus contribute to the measurement of ecological integrity and sustainability.

Sustainable development indicators measure sustainability or sustainable development performance. Since most environmental indicators have a sustainable development framework in which environmental, economic and social indicators are linked they have been included. Measurement of sustainable development should be based on indicators which signal [29]:

- (1) the pressure that society puts on the environment, in the form of pollution and resource depletion,
- (2) the resulting state of the environment, especially the incurred changes, compared to desirable or sustainable states, and
- (3) the response by human activity mainly in the form of political and societal decision, measures and policies.

This approach relates to the presentation of causes and effects in Part 1 of this paper [1].

The United States Environmental Monitoring and Assessment Program (EMAP) at the Environmental Protection Agency (EPA) describes indicators as measurable characteristics of the environment, both abiotic and biotic, that can provide quantitative information on ecological resources. The objectives of the workgroup are to [30]:

- (1) Develop a *research strategy* that focuses research efforts on the development of needed ecological indicators and *reduces uncertainty associated with indicators already in use* (our italics).
- (2) Define categories of information that are critical to the development of indicators to provide a consistent basis for research development and scientific review of ecological indicators.
- (3) Provide technology transfer to regional, state and local groups who use ecological indicators in their regulatory and assessment programs as well as program offices and other agencies who have ongoing activities that influence the development and use of ecological indicators.

This indicates a serious ambition to further build up and improve the use of ecological indicators, and exergy, we would argue, is a strong candidate in this regard.

The “ecological footprint” of a specified population or economy can be defined as the area of ecologically productive land that would be required on a continuous basis to provide all energy and material resources consumed, and to absorb all the wastes discharged by that population, wherever on the earth that land is located. Its analysis should provide an estimate of how far to achieve sustainability. It can be used as an analytical tool to assess the sustainability of current human activities, and also an educational tool for public awareness, and decision-making [31]. A similar method was introduced

by Borgström as a “ghost area” needed to support a country with food that was offered from import, e.g., long distance fishing, and not from domestic production [32].

The aim of sustainable development studies is to find operational criteria of sustainable development by emphasizing the link between generated services and used resources. This makes exergy a good indicator, since higher exergy efficiency often means less exergy waste to environment, i.e., less environmental harm. Nilsson divides the resource base into social, material, and financial resources and states three key ratios [33]:

- (1) Effectiveness ratio links the purpose of the operation to the services obtained by the operation: “Does the operation fulfill its purpose? Is the service provided by the operation worth the effort?”
- (2) Maintenance capacity links the size of the operation to the throughput between the operation and the resource base: “Is the operation making efficient use of available resource throughput?”
- (3) Margin links the throughput to the resource base: “Does the operation have integrity in relation to certain resources? Is there a risk of being forced to change habits? Are current habits, i.e., technology, sustainable?”

The Organization for Economic Co-operation and Development (OECD) spells out three major purposes of indicator development [15]:

- (1) Indicators for the measurement of environmental performance.
- (2) Indicators for the integration of environmental concerns into sector policies.
- (3) Indicators for the integration of environmental concerns into economic policies more generally, mainly through environmental accounting.

Three basic criteria have been used in OECD work: policy relevance, analytical soundness and measurability. In order to have a policy relevance and utility for users an environmental indicator should: provide a representative picture of environmental conditions, pressures on the environment or society’s responses; be simple, easy to interpret and able to show trends over time; be responsive to changes in the environment and related human activities; provide a basis for international comparisons; be either national in scope or applicable to regional environmental issues of national significance; have a threshold or reference value against which to compare it, so that users are able to assess the significance of the values associated with it. Analytical soundness implies: be theoretically well founded in technical and scientific terms; be based on international standards and international consensus about its validity; lend itself to being linked to economic models, forecasting and information systems.

TABLE I  
Eco-indicators 95 [34].

<i>Environmental problem</i>	<i>Emission per European individual (kg·year<sup>-1</sup>)</i>	<i>Evaluation weight factor</i>	
Green house effect	1310	GWP*	2.5
Depletion of the ozone layer	0.926	ODP*	100
Acidification	113	AP*	10
Eutrofication	38.2	NP*	5
Heavy metals	0.0543	Pb-equiv.	5
Carcinogenic	0.0109	PAH*-equiv.	10
Winter smog	94.6	SO <sub>2</sub> -equiv.	5
Summer smog	17.9	POCP*	2.5
Pesticides	0.966	useful substance	25

\* Where GWP = Global Warming Potential, ODP = Ozone Depletion Potential, AP = Acidification Potential, NP = Nitrification Potential, PAH = Poly-Aromatic Hydrocarbons, POCP = Photochemical Ozone Creation Potential.

Measurability implies that the data required to support the indicator should be: readily available or made available at a reasonable cost/benefit ratio; adequately documented and of known quality; updated at regular intervals in accordance with reliable procedures. The exergy concept fulfills most of these criteria.

The eco-indicator 95 (EI95) evaluation method [34] has been used to express environmental problems in one indicator by multiplying the normalized values with a specific factor (evaluation weight factor) as listed in *table I*, which is determined by how far the environmental effect is away from the desired level. The listed nine environmental effects are normalized by estimating the average value of what each European individual add to the specific environmental problem on a yearly basis.

The problem associated with this evaluation method is that the determination of the desired level for the different environmental effects is a subjective process. The death of 1 human being per million has been attributed the same weight in the evaluation method as damaging 5% of an ecosystem [34]. Below we will compare eco-indicator 95 with exergy as an ecological indicator.

### 3. LIFE CYCLE ANALYSIS AND EXERGY

In Part 1 [1] we introduced the concept of exergy and we classified resources into natural flows, funds and deposits. We also studied the use of exergy in nature and society in order to point out specific differences that relate to sustainable development. In this section we will bring the use of exergy further into this area by introducing it into already used methods.

An emission in complete equilibrium with its environment does not have any exergy. There is no difference in temperature, pressure, or concentration etc. that can drive any processes, i.e., have any effect on the environment. The more exergy an emission carries, the more it deviates from the environment. An emission of substances, that are common in the environment, e.g., steam or water, carries less exergy than emissions of substances that are less common, e.g., heavy metals or radioactive waste. Simultaneously, the exergy represents physical value, i.e., that a substance is technically useful and therefore should have an economic value and should be worth taking care of. Thus, emissions of high exergy substances should also be regarded as a misuse of resources.

Environmentally oriented Life Cycle Assessment (LCA) analyzes environmental problems associated with the production, use and disposal or recycling of products or product systems, see *figure 1*. Most products can be divided into three "life processes", or as it is sometimes named "from cradle to grave".

For every "life process" the total in and out flows of energy and material is computed, thus, LCA is similar to an energy or exergy analysis that was introduced in the mid-seventies [35, 7, 36, 5, 9]. In general exergy analysis and life cycle analysis have been developed separately. This inventory of energy and material balances is then put into a framework as described in *figure 2*. Usually four parts can be distinguished in the LCA:

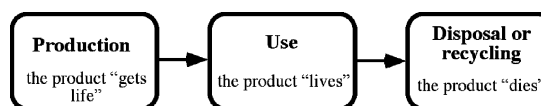

Figure 1. The life cycle of a product.

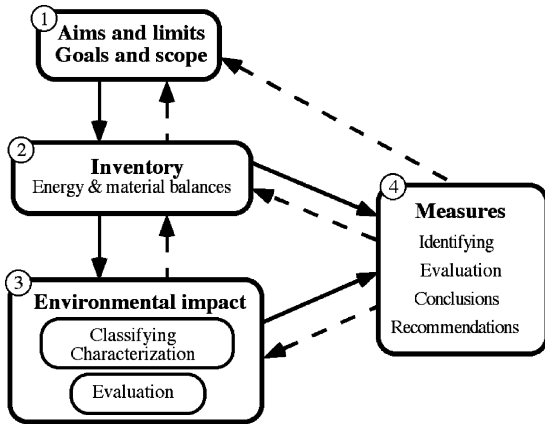

Figure 2. The four main steps of a LCA.

- (1) aims and limits or goals and scope,
- (2) inventory,
- (3) environmental impact, and
- (4) measures.

In Part 1 [1] the subject of study is determined in relation to the application intended. The functional unit of the product, the spatial scale and time horizon have to be determined. In the inventory analysis the complete life cycle of the product is analyzed leading to the inventory table, a list of inputs from and outputs to the environment. The environmental impact assessment is a stepwise process. In the first step, the classification, it is determined which environmental effects are considered and which extractions and emissions contribute to it. In the second step, the characterization, the contribution of all extractions and emissions to the selected environmental problem is estimated. For a better interpretation, the impact of the environmental effects can be normalized to the actual impact in some given area. The final step is the valuation of the selected environmental problems. The last part of the LCA is the improvement analysis. Boxes indicate these four main parts of a LCA, and arrows show the procedure. Solid arrows shows the basic steps and dashed arrows indicates suitable next steps, in order to further improve the analysis.

In LCA the environmental burdens are associated with a product, process, or activity by identifying and quantifying energy and materials used and wastes released to the environment and to assess the impacts of those energy and material uses and releases to the environment. Thus it is divided into several steps as is seen from figure 2. The analysis should cover impacts associated with the three “Areas for protection”:

- (1) resources,
- (2) human health, and

- (3) ecological health [37].

Exergy offers several additions in LCA, e.g., as a uniform indicator of total environmental impact or when performing an improvement assessment for identifying real losses. To some extent this makes other indicators in the LCA superfluous. Exergy may also be used as a measure of the depletion and use of both energy and material resources.

When we discuss resource depletion caused by consumption, it is neither matter, since matter can only be transformed, not destroyed (nuclear reactions excluded), nor energy which cannot be depleted or consumed. But the physical utility, which is measured by the exergy, is consumed and may become depleted. For a material to be useful, it must normally be concentrated, structured and ordered with respect to the surroundings. A well-known scientific quantity that is often interpreted as a measure of the disorder of a system is entropy. If a material is to be useful, it must normally have a lower entropy than the surroundings. Societies and technical systems can be described as feeding on low-entropy matter and energy converting it to high-entropy matter and energy. The entropy production may therefore be a useful indicator of resource consumption in connection with LCA. The exergy concept provides an effective means of incorporating the value of the entropy concept in an ecological indicator, since it does provide an easily understandable meaning in ordinary life.

Exergy can also be used as a more general criterion, in order to point out where large emissions may be prevented or separated and transformed into harmless waste or useful products. For sustainable development the destruction of the exergy reservoirs of natural resources has to be minimized to a level at which there is no damage to the environment and at which the life support systems to future generations is secured.

Cornelissen [10] has developed a method called Exergetic Life Cycle Analysis (ELCA). However, he makes no distinction between abiotic and biotic resources, the reasons are:

- (1) In many situations in the present society abiotic resources are used to obtain biotic resources, so to make a distinction between these two types of resources becomes less meaningful.
- (2) To simplify the analysis. Exergy destruction is used as a single criterion for the depletion of natural resources. However, in later work Cornelissen and Hirs have also introduced a distinction between renewable and non-renewable resources [38].

The framework of the ELCA and the LCA are similar. The definition of goal and scope of the LCA and ELCA

are completely identical. The inventory analysis of the ELCA is more extensive. A complete flow-sheet of the mass and energy streams of the different production steps is required. The material and energy flows should be balanced. This is not always the case in a LCA. Also the more simplified black box approach can be used of which only the inputs and outputs of the production processes are taking into account. The impact assessment is limited to calculation of the exergy of the flows and the determination of the exergy destruction in the different processes. There is no classification in the ELCA. For the calculation of exergy the conditions and composition of the environment have to be specified. For processes where no location is specified it is recommended to use the standard state established by Szargut et al. [39]. The cumulation of all exergy destruction in the life cycle gives the life cycle irreversibility of the product. The improvement analysis is the minimization of the life cycle irreversibility [10]. In a similar method, the authors [11] make a clear distinction between renewable and nonrenewable resources in order to evaluate the sustainability of a process or activity. This method has its roots in the earlier work on exergy analysis by Wall [5], and may be regarded as an application of exergy to LCA and is referred to as Life Cycle Exergy Analysis (LCEA), which will be further described below.

Stougie et al. [40] have performed a study to relate exergy loss with different environmental effects. Their conclusion is that there is a qualitative relation, but that more research is needed to determine a quantitative relation. Blonk et al. [41] have analyzed the feasibility of making operational the depletion of abiotic resources in LCA via the key resources energy and land. They investigate

the use of exergy loss as an indicator. However, one of their criteria for the characterization was that the indicator should be independent of the location and the way of refining of materials. This is not the case with exergy analysis and they concluded that the exergy loss approach was not useful as an indicator within this framework.

To find all exergy that is used in a production process, it is necessary to take all different inflows of exergy in the process into account. In 1974, a conference was held by the International Federation of Institutes for Advanced Studies (IFIAS) at which this type of budgeting was denoted energy analysis, and Gibbs free energy was chosen as a unit of measure [7]. It has been suggested to use exergy instead and call the method exergy analysis [5].

There are basically three different methods used to perform an exergy analysis. These methods are process, statistical and input-output analysis [9]. The latter is based on an input-output table as a matrix representation of an economy. Each industry sector is represented by a row and column in the matrix. The main advantage of this method is that it can quickly provide a comprehensive analysis of an entire economy, and the main disadvantages results from the use of financial statistics and from the degree of aggregation in the table. In order to obtain a more detailed disaggregation than used in input-output tables it may be sufficient to make use of the more detailed statistics from which input-output tables are usually compiled. The method is called statistical analysis, which is basically a longhand version of input-output analysis. This method has two advantages over the input-output method:

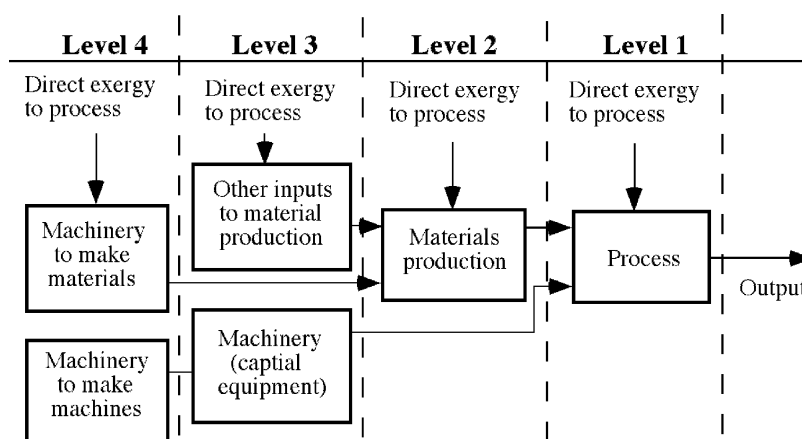
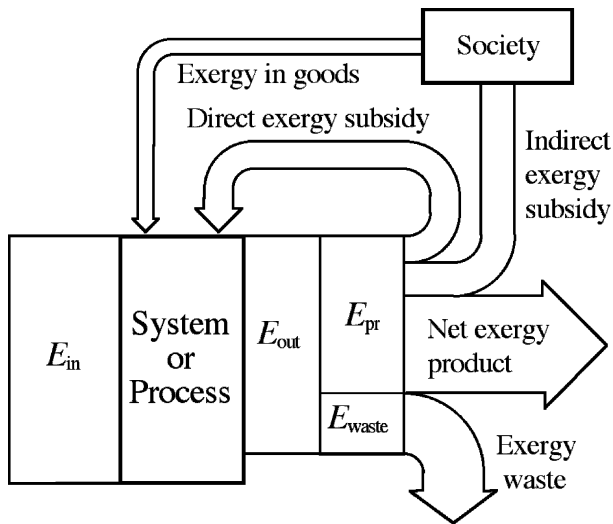

Figure 3. The levels of an exergy process analysis.





**Figure 4.** Net-exergy analysis. The output is distributed among exergy waste, net exergy product, indirect exergy subsidy and direct exergy subsidy. The exergy destruction, i.e., the irreversibility is indicated by the difference in exergy inflow  $E_{in}$  and exergy outflow  $E_{out}$ .

- (1) it can achieve a more detail analysis, and
- (2) it can usually be executed directly in physical units, thus avoiding errors due to preferential pricing, price fluctuations, etc.

However, its disadvantage compared to the input-output method is that the computations usually have to be done manually. Process analysis, [7] see figure 3, focuses on a particular process or sequence of processes for making a specific final commodity and evaluates the total exergy use by summing the contributions from all the individual inputs, in a more or less detailed description of the production chain. Szargut introduced the concept of cumulative exergy consumption [42, 43], to express the sum of the exergy of natural resources consumed in all steps of a production process. This concept is analogous to the exergy process analysis.

Also, the more clarifying name net-energy analysis has been used for this kind of analysis [44]. This method is described in terms of exergy in figure 4. All exergy being used, directly or indirectly, in the production of the product will be deducted from the exergy of the product to define the net exergy product.

The multidimensional approach of LCA causes large problems when it comes to comparing different substances, and general agreements are crucial. This problem does not occur in ELCA and LCEA, since all energy and material stream are measured in the same quantity, namely exergy.

#### 4. LIFE CYCLE EXERGY ANALYSIS (LCEA)

In LCEA, physical resources are classified into natural exergy flows, exergy funds and exergy deposits, see Part 1 [1]. Natural exergy flows and sustainable use of exergy funds establish the renewable resources. Unsustainable use of exergy funds, e.g., careless clearing of forests, and exergy deposits make up for the non-renewable resources. The total exergy use over time is also considered. This kind of analysis is helpful in developing sustainable energy supply systems in society. The exergy flow through a supply system, such as a power plant, usually consists of three separate stages over time, see figure 5. At first, we have the construction stage where exergy is used to build a plant and put it into operation. During this stage,  $0 \leq t \leq t_{start}$ , exergy is spent of which some is accumulated or stored in materials as metals. Secondly we have the maintenance of the system during time of operation, and finally the clean up stage. These stages are analogous to the three steps of the life cycle of a product in a LCA. The exergy input used for construction, maintenance and clean up we call indirect exergy  $E_{indirect}$ . This may originate from both renewable and non-renewable resources. When a power plant is put into operation, it starts to deliver a product, e.g., electricity with exergy power  $\dot{E}_{pr}$ , by converting the direct exergy power input  $\dot{E}_{in}$  into demanded energy forms as electricity. Let us now look at two cases,

- (1) the direct exergy input is a deposit, i.e., a non-renewable resource as fossil fuel and
- (2) the direct exergy input is a natural flow, i.e., a renewable resource as wind.

In the first case, the system is not sustainable, since we use exergy originating from a deposit, which by definition is a non-sustainable resource, see figure 5. We will never reach a situation where the total exergy input will be paid back, simply because the situation is powered by a depletion of resources, we have  $E_{pr} < E_{in} + E_{indirect}$ . In the second case, instead, at time  $t = t_{pay\ back}$  the produced exergy that originates from a natural flow has compensated for the indirect exergy input, see figure 6, i.e.,

$$\int_{t_{start}}^{t_{pay\ back}} \dot{E}_{pr}(t) dt = \int_0^{t_{life}} \dot{E}_{indirect}(t) dt = E_{indirect} \quad (1)$$

Since the exergy input originates from a natural flow, i.e., a renewable resource, it is not accounted for in the analysis, it is regarded as a free resources, see figure 6. In principle, the output exergy originating from a renewable source can replace the input of non-renewable resources

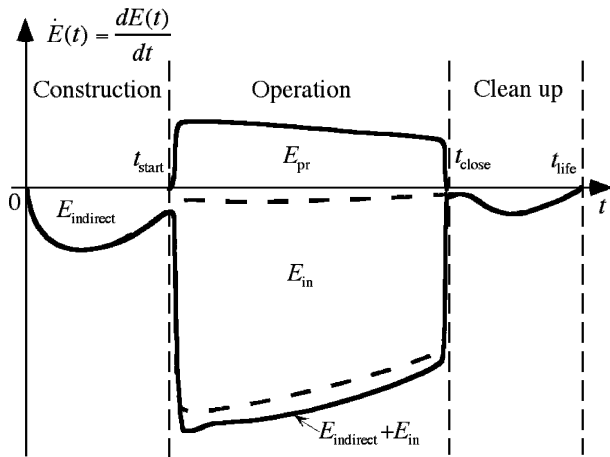

Figure 5. Exergy use during a systems life cycle.

that may occur in the indirect exergy. If this is done this would also make the production of the power plant itself sustainable. As long as we distinguish between non-renewable and renewable resources the accounting may, of course, be done differently. By regarding renewable resources as free after  $t = t_{\text{pay back}}$  there will be a net exergy output from the plant, which will continue until it is closed down, at  $t = t_{\text{close}}$ . Then, we have to use exergy for clean up and restore of the environment, which accounts for the last part of the indirect exergy input, i.e.,  $E_{\text{indirect}}$ , which is already accounted for, see equation (1). By considering the total life cycle of the plant the net produced exergy becomes:

$$E_{\text{net, pr}} = E_{\text{pr}} - E_{\text{indirect}} \quad (2)$$

The areas representing exergies are indicated in figure 6.

Let us assume a wind power plant. At time  $t = 0$  we decide to build the plant that is put into operation at time  $t = t_{\text{start}}$ . At that time a large amount of exergy has been used in the construction of the plant, which is indicated by the area of  $E_{\text{indirect}}$  between  $t = 0$  and  $t = t_{\text{start}}$  in figure 6. This exergy may originate partly from renewable and partly from non-renewable resources. At  $t = t_{\text{start}}$  the plant starts to produce electricity, which is indicated in figure 6 by the upper curve  $E_{\text{pr}} = E_{\text{indirect}} + E_{\text{net, pr}}$ . At  $t = t_{\text{pay back}}$  the exergy used for construction, maintenance and clean up has been paid back. For modern wind power plants this time is only some months. Then the system has a net output of exergy until it is closed down, which for a wind power station may last for decades. The input of wind exergy is not accounted for since it is regarded as free. All input of exergy to the plant, i.e., indirect exergy, has been compensated for by the product and we are left with a net gain, i.e., net exergy

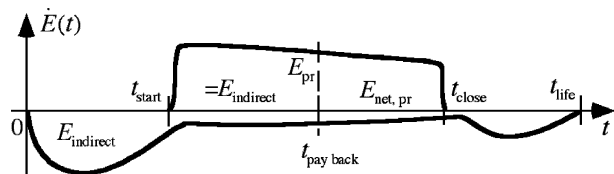

Figure 6. Exergy use based on renewable resources during a systems life cycle.

product  $E_{\text{net, pr}}$ . Thus, these diagrams may be useful in order to indicate sustainable development.

Life cycle exergy analysis is very important in the design of sustainable systems, especially in the design of renewable energy systems. Consider a solar panel, made of mainly aluminum and glass, that is used for production of hot water for household use, i.e., about 60 degrees Celsius. In this case, it is not obvious that the exergy being spent in the production of this unit ever will be paid back during its use, i.e., it might be a misuse of resources rather than a renewable resource use. The production of aluminum and glass require a lot of exergy as electricity and high temperature heat of several hundred degrees Celsius, whereas it will only produce hot water, i.e., exergy of low value. Thus, it may well be better to use the spent resources to produce hot water directly, e.g., with a heat pump, instead of first making a solar panel. Life cycle exergy analysis must therefore be done in the design of such systems in order to avoid these kind of mistakes.

Sustainable engineering could be defined as systems which make use of renewable resources in such a way that the input of exergy will be paid back during its life time, i.e.,  $E_{\text{pr}} > E_{\text{in}} + E_{\text{indirect}}$ , and the used deposits are completely restored or even better not used at all. Thus, by using LCEA and distinguishing between renewable and non-renewable resources we have a method to define sustainable engineering.

Blinge has successfully developed a method, Energy Logistic Modeling (ELM), which is basically an adaptation and a specification of the general LCA methodology to the field of fuel supply systems [45, 46]. Blinge points out that exergy could easily be incorporated into this method. The visualization is based on three basic logistic terms: transportation, storage, and refinement. In the ELM these have been complemented with the material properties before entering and after leaving the refinement process. These are in ELM called raw material, additives, by-products and end use, i.e., as emissions after being used in a vehicle, see figure 7.

The ELM aims at answering either or both of the following questions:

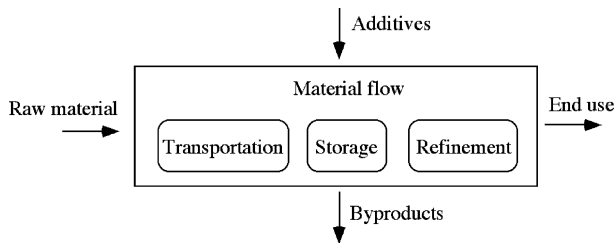

Figure 7. The division of the production processes into subsystems in ELM [46].

(1) Which of the analyzed fuels is the most energy/exergy effective and emits least of the analyzed air pollutants when it is produced in a defined amount, with defined production process, from defined raw materials and used in equally comparable vehicles?

(2) What is the environmental load, i.e., energy/exergy utilization and analyzed air pollutants for a fuel when it is produced in a defined amount, with a defined production process, from defined raw materials and used in defined vehicles and what improvement possibilities does this system have?

Energy Logistic Modeling (ELM) for motor fuels describes a method for analyzing energy and exergy utilization and emissions for a fuel that is made from a defined raw material, with defined production processes, located at specific places and used by specific users, e.g., vehicles, vehicle fleets and vehicle categories. The reason for this very precise definition of the production and user chain is that the result of an LCA of a motor fuel varies so much that an overall result for a motor fuel valid all over the world is impossible to establish. The result of an LCA of a motor fuel is dependent on several factors, e.g., what amount of fuel that is desired, what kind of raw material and energy that is used, in what form it exists, where raw material, production and end use are located, etc.

ELM is based on a systems approach, logistics for manufacturing industry and LCA. ELM has been developed to model and analyze the environmental impact from the production and use of all kinds of motor fuels. An extension of analyzed emission to air, ground and water can be made. Also, factors that normally are not quantified in LCA, e.g., infrastructure, accidental spills, environmental impacts caused by personnel and human resources [47] can be considered in an extended version of the model. ELM must also be continuously updated according to the new findings and standards that are the result of the progressing development in the field of LCA.

In order to lower the resource use in the transportation sector it is important that the exergy is used in an effective way. Based on the data from a study of Blinge et al.

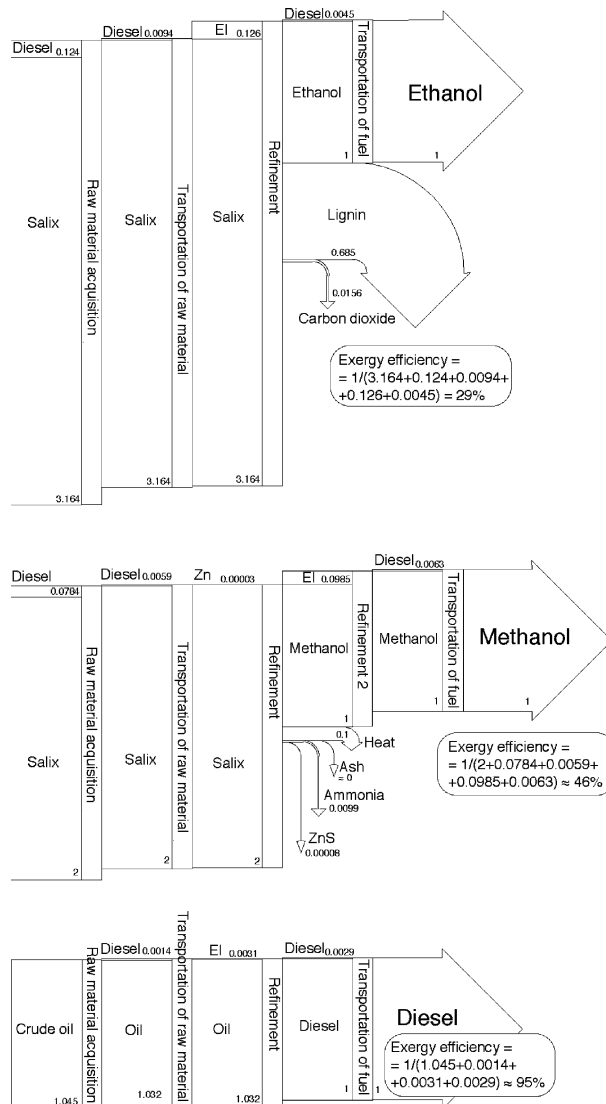

Figure 8. Exergy analysis of ethanol, methanol and diesel use for transportation. The exergy efficiency is given by the net exergy product divided by the total exergy input in all steps of the production process. Exergy waste flows are indicated by the bended flows and the exergy destruction is indicated by the difference in exergy inflow and exergy outflow at every process step.

[48] the exergy efficiencies for three alternative fuels has been calculated, namely: ethanol from wood (salix), produced by an enzyme process, methanol from salix and diesel oil, see figure 8. The exergy efficiencies are 29% for ethanol or 36% if the lignin is used, 46% for methanol and 95% for diesel. From these diagrams we also see the exergy of the emissions, e.g., carbon dioxide, heat, and ammonia. Even though this method is used for motor fuels, it can be applied to other fields. However,

only ethanol and methanol may be regarded as almost sustainable system since salix is a renewable resource and the exergy of the produced fuel compensates for the indirect exergy input of mainly deposits. However, many objections may be raised, e.g., farmland is used for production of fuel instead of food in a world of poverty and starvation, which makes this into a moral issue. Thus, exergy evaluations are not enough to judge if a system is sustainable in all respects or not, however, most certainly necessary.

### 5. EXERGY FLOW DIAGRAMS

Again, we want to further point out the usefulness of exergy flow diagrams as an ecological indicator. This usually gives much more information than just a number. *Figure 9* is the average exergy flow through a car based transportation system. Thus, it exemplifies how the fuel output in *figure 8* could be used. The transportation system accounts for a great deal of the fuel use in the society. Gasoline and oil are converted into transport work in cars, buses, trucks etc. About 10% of the exergy content of the fuel is used to run a vehicle, i.e., for acceleration and to overcome the air resistance, see *figure 9*. The net output as transport of people and goods is often less than 1%. The rest of the input exergy is either lost from irreversibilities or emitted to the environment as exergy waste, e.g., heat, pressure-volume work to the atmosphere, combusted and non-combusted emissions in the exhaust gases. *Figure 9* shows how these emissions are distributed. In addition to these emissions there are emissions from the wearing out of brakes and tires, etc. The total resource use also includes about the same

amount of exergy for manufacturing and maintaining cars, roads, etc., which also adds exergy emissions to the environment.

Exergy flow diagrams also give an indication of the ecological effects due to the resource use and the efficiency of this use. Processes with large exergy losses from irreversibilities will have a large indirect impact on the environment since they use a large amount of resources, especially if these resources originate from deposits. Thus, the flows should be separated with respect to their origin; natural flow, funds or deposits, see *figure 10*.

Wall has applied exergy flow diagrams to the total use of physical resources for a number of societies [5, 4, 49-51]. Recently Ertesvag and Mielnik performed a similar study for Norway [52]. The main conversions of energy and materials in the Swedish society in 1994 is shown in *figure 10* [24]. The flows of resources go from left to right in the diagram, i.e., from the resource base to the consumption sector. Thus, the diagram basically represents the supply sector. The width of the flows are J/year and they are ordered according to their origin. Sunlight is thus a renewable natural flow. Harvested forests, agricultural crops, and hydropower are renewable exergy flows deriving from funds. Iron ore, nuclear fuels, and fossil fuels are non-renewable exergy flows from deposits, which are exhaustible and carriers of toxic substances. Exergy conversions are represented by the unfilled boxes, which in most cases represents a huge number of internal conversions and processes. The exergy demand in the society appears as outflows on the right side of the diagram. The overall efficiency of the supply sector is only about 15%. Some sectors have a far less efficiency, in some cases ridiculously poor. For nuclear fuel to space heating through short circuit heaters the utilization is less than 0.025% or 250 ppm [24]. These diagrams offer a good description of the level of sustainability with respect to physical resources use of a society, since the dependence on deposits, i.e., non renewable resources, is visualized. The exergy flows of emissions could be added to these diagrams to give a more complete picture of the environmental effects.

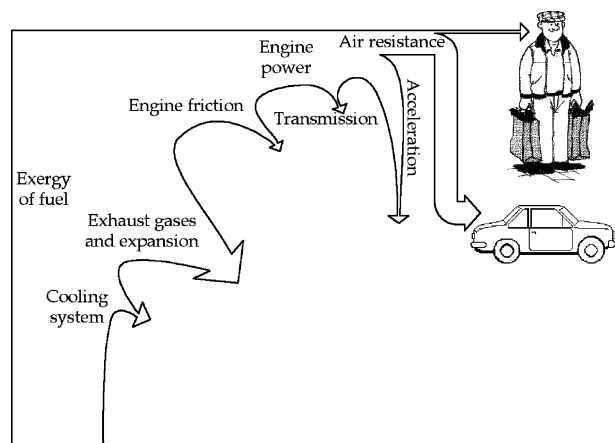
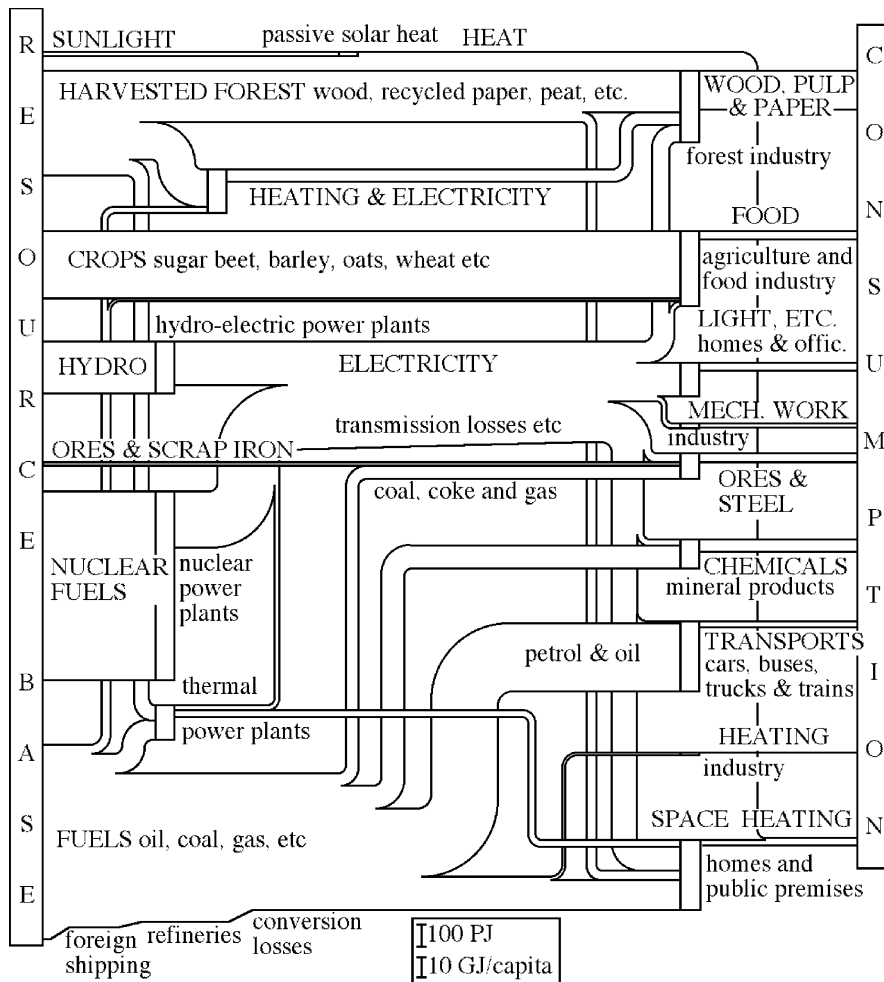

Figure 9. Exergy flow through a car.

A method that also deserves to be mentioned here is the Energy Utility Diagrams (EUD), which is a very powerful method to analyze the exergy distribution among the components of a process [53]. By adding the exergy emissions to the environment from each component and separating between renewable and non-renewable resources this might be a suitable method for process optimization and helping support sustainable development.



**Figure 10.** The exergy use in the Swedish society in 1994. The total inflow was about 2720 PJ or 310 GJ/capita and the net output was 380 PJ or 40 GJ/capita [49]. The exergy destruction is indicated by the difference in exergy inflow and exergy outflow at every conversion process that is indicated by the empty rectangles.

Exergy is a unique and valuable ecological indicator since it is also very useful in the design process. By minimizing the exergy losses in a process the exergy to the environment as waste is also minimized, and often also the environmental effects. However, there are limitations. The exergy of a compound can't be consistently associated with that compound's potential to harm the environment. Hence, the avoidance of exergy emissions resulting from depletion avoidance measures such as increased cycling or cascading can't be directly associated with environment benefit. For instance, benzene, lead, aluminum, ammonia, and hydrochloric acid all have large exergy, but vastly different potential and mechanisms for harming the environment. If this harm can be measured in terms of

an exergy destruction, this could be linked to the exergy of a waste, in the same way as electric conductors are classified with respect to their exergy destruction when used as conductors. A good conductor has a high conductivity and generate minor exergy destruction whereas a bad conductor generate heavy destruction. Thus a "bad" waste will create heavy exergy destruction in the environment, and this could be linked to the exergy of the waste as an additional exergy fee.

Another approach to this problem has been pointed out by Ayres et al. [54]. Exergy calculated with respect to macro-environments, such as the atmosphere, the ocean, or the earth's crust is not a straightforward measure of the effect on biological organisms. To extend the concept

into the realm of biological disturbances (toxicity) would necessitate defining an appropriate internal environment for each organism (such as blood or lymph), or even an intracellular environment. The conclusion is that, it is an important task to find out how to evaluate environmental harm in terms of exergy. Wall [5], Ayres and Masini [55] have also raised the suggestion of defining a local environment as reference. The main reason is that the reference states defined by Szargut et al. [39] sometimes are too simplified, with regard to some of the major biological active elements and compounds found in pollutants.

## 6. EXERGY AS AN ECOLOGICAL INDICATOR

Finally, we will describe exergy as an ecological indicator. In figure 11 EI95 and exergy are compared for a porcelain mug and 3000 polystyrene cups, data originates from Cornelissen [10]. The emissions in mass are over 98 percent CO<sub>2</sub>. The emission of CO<sub>2</sub> accounts for more than 70% of the exergy waste for the porcelain mug, whereas only about 16% from the EI95 evaluation. The largest emission in the EI95 evaluation is NO of about 37%. However, in the exergy case NO only amounts to about 3%. When it comes to the comparison between the porcelain mug and the polystyrene cups, the EI95 gives a lower number for the porcelain mug, 0.0365 compared

to 0.101, i.e., the polystyrene cups are almost three times as harmful as the porcelain mug. A similar comparison of the exergy emissions also gives a better score for the porcelain mug, or 18.9 MJ compared to 31.6 MJ for the polystyrene cups. However, the difference is not as large as in the EI95 case. By evaluating the exergy destruction of these emissions and adding this to the exergy of the waste as was described above, the present differences between the EI95 and the exergy study will probably become less. Thus, exergy would be a better measure of harmfulness that is illustrated in the comparison above. However, this kind of exergy studies requires more research, data and agreed standards to become a more reliable method of evaluating the total environmental impact of a process or product.

For every real process the sum of the exergy of the product  $E_{pr}$  and of the waste  $E_{waste}$  is always less than the exergy input  $E_{in}$ . To calculate the exergy of the waste we need a detailed knowledge of the chemical composition of the waste stream. However, for many chemical and metallurgical processes it is difficult to obtain reliable data on the chemical composition of the wastes. To simplify the composition of the waste stream it can be estimated approximately, just using the basic and important chemical compounds, temperatures, pressures, and so on.

Figure 12 demonstrates chlorine production in terms of exergy flows, with data from Ayres et al. [54]. The exergy values are calculated from exergy tables [39, 56]. The use of exergy analysis offers a number of advantages over the standard approach using energy and mass, separately.

(1) An indication of the theoretical potential for future improvement for a process is provided by the exergy efficiency, which becomes  $7027/16450 \times 42.7\%$ .

(2) By using exergy the comparison of different kinds of materials become possible. The exergy embodied in the emission, together with an estimation of the exergy destruction it will cause in the environment, offers a fairly reliable measure of the potential for environmental harm, see above.

(3) The third advantage of using exergy in the context of LCA really follows from the second, i.e., it provides a unitary measure that can be used for year-to-year environmental performance comparisons of large firms, industries or nations. A time-series of exergy based assessments of the aggregate efficiency and waste generation of a multi-product firm, or an industry such as pulp and paper or petroleum refining (or single firm in one of these industries) would be a valuable supplement to the sort of

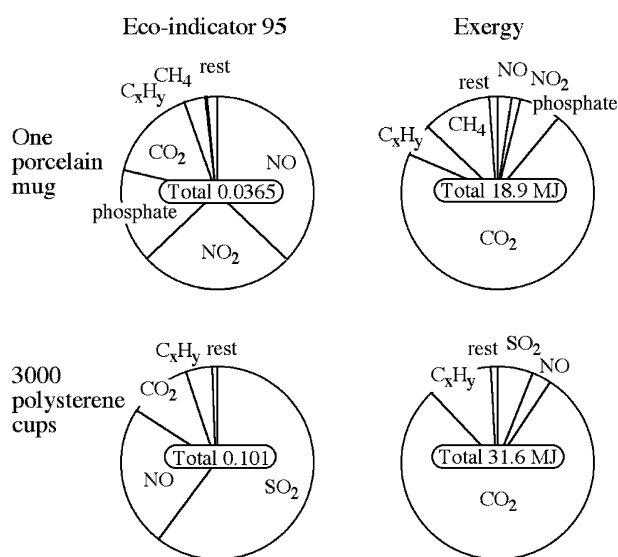
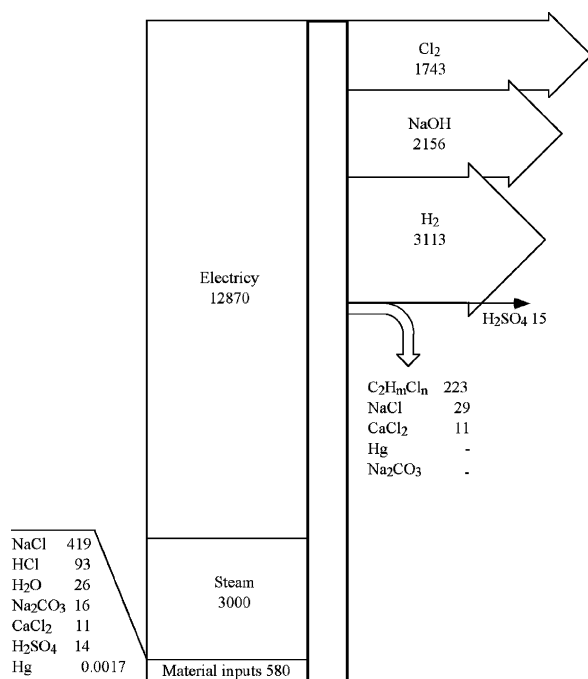

Figure 11. Eco-indicator 95 versus exergy of the emissions from the production of a porcelain mug and 3000 cups of polysterene cups.



**Figure 12.** An Exergy flow diagram of a chlorine production process. Data from Ayres et al. [54]. 1 kg of Cl produced and units in kJ. Total input 16450, product 7027 (43%) and 264 (1.6%) as waste. Exergy waste flows are indicated by the bended flows and the exergy destruction is indicated by the difference in exergy inflow and exergy outflow of the process.

advertising-style environmental report that is typically issued today.

(4) On the life cycle level, exergy can very well take into account the “hidden” energy in substances. For instants, in the production of polymers, this term is even more prominent. In the production of 1 kg of polyethylene, about 1.1 kg of oil will be needed. It would be completely false to appoint 1.1 kg of oil as the energy use of the process, since most of the substances in the oil will remain as chemical substances in final product. The energy is not lost, but it is restructured into new chemicals. The traditional distinction between energy and material may be misleading. This problem is simply avoided by applying exergy, since, all forms of energy, material and even information are just carrier of exergy, that may transfer between these forms. The use of exergy calculations will yield a consistent way of taking into account the exergy stored in the polymer during its whole life cycle. Since exergy calculations provide a more rational way of accounting losses on the process level, the accumulation of these processes in the life cycle calculations will also yield more realistic results.

## 7. CONCLUSIONS

The concept of sustainability needs a clear definition. Thus, the definition offered by Delin [25] is recommended for several reasons. Firstly, it is an elegant and concise definition, and secondly, it offers a strict and precise measure which is easy to apply to real processes and systems. Also, this definition is less easily manipulated by political or economical arguments.

A serious shortage with most of the methods presented in this paper is the lack of acceptance outside the research field. Most of the methods must be further simplified, in order to reach a common acceptance. The result of an LCEA and exergy flow diagrams are easy to understand, however, the exact calculations are too complicated for common use. Exergy evaluations of emissions should be standardized, and user-friendly computer programs should be developed. Methods to add the environmental impact to the exergy of emissions must be further elaborated. The ELM, which has been applied to the transportation sector should be developed and applied to other fields. Exergy has been applied to a number of different areas with different methods. The results from these methods are not immediately comparable. Thus, general guidelines should be developed. A common problem in most of the referred studies is the lack of data. Thus, data suitable for exergy studies should be made available.

It is important to economically stimulate improved exergy efficiency and use of renewable resources. Therefore, all use of deposits could be subject to a tax according to the amount of exergy used [57, 58]. All waste products could also be taxed by the amount of exergy released in the environment, since this is related to the environmental impact. In addition to this sometimes tax or restrictions should be added due to other effects, e.g., toxicity and explosives. *Figures 1 and 12* in Part 1 [1] of this paper showed how the lack of recycling in the society creates resource depletion and environmental destruction. By an exergy tax this could be changed. This tax could be used to support research and other activities to improve the sustainability by increasing exergy efficiency and supporting the use of natural flows and funds. This tax should be governed by an international organization, e.g., the United Nations, since the effects usually are global. An exergy tax supports companies based on renewable resources and no harmful waste production, thus, it would help stimulate the development of a sustainable society.

### Acknowledgements

This paper partly originates from our work within the Encyclopedia of Life Support Systems (EOLSS) and the Encyclopedia of Desalination and Water Resources (DESWARE), see <http://www.eolss.com/>. We want to express our gratitude to the International Centre for Water and Energy Systems in Abu Dhabi, UAE for the kind support of our work and the permission to use it for this paper.

### REFERENCES

- [1] Wall G., Gong M., On exergy and sustainable development—Part 1: Conditions and concepts, exergy, Internat. J. 1 (3) (2001), in press.
- [2] Tolba M., Ed., Our Fragile World—Challenges and Opportunities for Sustainable Development, EOLSS Publ., Oxford 2001, in press.
- [3] Larkin M., Heart B., The Wind is My Mother: The Life and Teachings of a Native American Shaman, Crown Publishing Group, New York, 1996.
- [4] Morgan M., Mutant message down under: a woman's journey into dreamtime Australia, Thorson, London, 1995.
- [5] Wall G., Exergy—a useful concept within resource accounting, Report No. 77-42, Institute of Theoretical Physics, Göteborg, Sweden, 1977, <http://www.exergy.se/ftp/paper1.pdf>.
- [6] Wall G., Exergy—a Useful Concept, Ph.D. thesis, Chalmers University of Technology, Sweden, 1986, <http://www.exergy.se/goran/thesis/index.html>.
- [7] IFIAS (International Federation of Institutes of Advanced Study), 1974, Energy Analysis, Workshop reports, Report 6 (1974) and Energy Analysis and Economics, Report 9 (1975).
- [8] Lovins A.B., Soft Energy Paths: Toward a Durable Peace, Harmondsworth, 1977.
- [9] Chapman P.F., Roberts F., Metal Resources and Energy, Butterworths, 1983.
- [10] Cornelissen R.L., Thermodynamics and sustainable development—the use of exergy analysis and the reduction of irreversibility, Ph.D. thesis, University of Twente, The Netherlands, 1997.
- [11] Gong M., Wall G., On exergetics, economics and optimization of technical processes to meet environmental conditions, in: Cai R. et al. (Eds.), Proceedings of Thermodynamic Analysis and Improvement of Energy Systems, 10–13 June, Beijing World, China, 1997, pp. 453–460 <http://www.exergy.se/ftp/exeopt.pdf>.
- [12] Encyclopedia of life support system (EOLSS), <http://www.eolss.com>.
- [13] Japan national institute for resources and environment (NIRE), [http://www.nire.go.jp/eco\\_tec\\_e/index-e.htm](http://www.nire.go.jp/eco_tec_e/index-e.htm).
- [14] Connelly L.G. (III), Reconciling consumption and conservation: Using an exergy-based measure of consumption to strengthen the conceptual framework of industrial ecology, Ph.D. thesis, University of California, Berkeley, 1998.
- [15] OECD (Organization for Economic Co-operation and Development), Environmental Indicators: OECD Core Set, OECD, Paris, 1994.
- [16] The Sustainable Seattle 1993: Indicators of Sustainable Community—A Report to Citizens on Long-term Trends in Our Community, Settle, USA, 1993.
- [17] IUCN, UNEP and WWF, World Conservation Strategy: Living Resource Conservation for Sustainable Development, International Union for Conservation of Nature and Natural Resources, IUCN, Gland, 1980.
- [18] WCED (The World Commissions on Environment and Development), Our Common Future, WCED, Oxford Univ. Press, 1987.
- [19] Holmberg J., Socio-Ecological Principles and Indicators for Sustainability, Ph.D. thesis, Chalmers University of Technology, Sweden, 1995.
- [20] <http://www.naturalstep.org/>.
- [21] Peet J., Energy and the Ecological Economics of Sustainability, Island Press, 1992.
- [22] Pirsig R., Lila: An Inquiry into Morals, Bantam Press, 1992.
- [23] Quinn D., Beyond Civilization: Humanity's Next Great Adventure, Harmony Books, 1999.
- [24] Wall G., Energy, society and morals, J. Human Values 3 (1997) 193–206, <http://www.exergy.se/ftp/esm.pdf>.
- [25] Delin S., personal communication, 1998, <http://w1.855.telia.com/ü85510800/>.
- [26] Jørgensen S.E., Exergy and ecology, Ecological Modelling 63 (1992) 185–214.
- [27] NDWP (Nevada Division of Water Planning), Water Words Dictionary, 1998, [http://www.state.nv.us/cnr/ndwp/dict-1/WORD\\_E.htm](http://www.state.nv.us/cnr/ndwp/dict-1/WORD_E.htm).
- [28] NCERQA (National Center for Environmental Research and Quality Assurance), Ecosystem Indicators, 1997, <http://es.epa.gov/ncerqa/rfa97/ecosystem.html>.
- [29] Hardi P., Pointer L., Models and methods of measuring sustainable development performance, in: Sustainable Development Coordination Unit, Executive Council, Government of Manitoba, Winnipeg, 1995, <http://iisd1.iisd.ca/ic/info/ss9504.htm>.
- [30] EPA, EMAP ecological indicator development, last updated 08/22/97, 1997, <http://www.epa.gov/emaps/html/indicator.html>.
- [31] Wackernagel M., Rees W., On Ecological Footprint: Reducing Human Impact on the Earth, New Soc. Publ., Gabriola Island, Canada, 1996.
- [32] Borgström G., Focal Points: A Global Food Strategy, Macmillan, New York, 1973.
- [33] Nilsson J., Biophysical indicators and sustainable development records for improved environmental management: Examples from municipalities and firms, Ph.D. thesis, Stockholm University, Sweden, 1997.
- [34] Goedkoop M., The Eco-indicator 95, Pré Consultants, Amersfoort, The Netherlands, 1995.
- [35] Berry S., Bull. Atomic Sci. 9 (1972).
- [36] Chapman P.F., Energy costs: A review of methods, Energy Policy 2 (1974) 91–103.
- [37] Finnveden G., Östlund P., Exergies of natural resources in life-cycle assessment and other applications, Energy 22 (1997) 923–931.



[38] Cornelissen R.L., Hirs G.G., The value of the exergetic life cycle assessment besides the LCA, in: Ishida M. et al. (Eds.), ECOS'99—International Conference on Efficiency, Costs, Optimization, Simulation and Environmental Aspects of Energy Systems, 8–10 June, Tokyo, 1999, pp. 282–286.

[39] Szargut J., Morris D.R., Steward F.R., Exergy Analysis of Thermal, Chemical, and Metallurgical Processes, Springer, Berlin, 1988.

[40] Stougie L., Dijkema G.P.J., Entropy or Exergy—an Environmental Indicator?, Interduct, Delft University of Technology, The Netherlands, 1994 (in Dutch).

[41] Blonk T.J., Davidson M.D., Lafleur M.C.C., Feasibility of Operationalization of Depletion of Abiotic Resources in LCA via the Key Resources Energy and Land, Working Document, IVAM Environmental Resources/CE, Amsterdam, 1997.

[42] Szargut J., Minimization of the consumption of natural resources, Bull. Polish Acad. Sci. Technical Sci. 26 (1978) 41–46.

[43] Szargut J., Morris D.R., Cumulative exergy consumption and cumulative degree of perfection of chemical processes, Internat. J. Energy Res. 11 (1987) 245–261.

[44] Spreng D.T., Net-Energy Analysis and the Energy Requirements of Energy Systems, Praeger, 1988.

[45] Blinge M., Energy logistics—LCA of fuels, Report 18, Dept. of Transportation and Logistics, Chalmers University of Technology, Göteborg, Sweden, 1993 (in Swedish).

[46] Blinge M., ELM: Environmental assessment of fuel supply systems for vehicle fleets, Ph.D. thesis, Dept. of Transportation and Logistics, Chalmers University of Technology, Göteborg, Sweden, 1998.

[47] Lindfors et al., Nordic guidelines on life-cycle assessment, Nordic Council of Ministers, Nord 20, Copenhagen, Denmark, 1995.

[48] Blinge M. et al., LCA of Fuels, The Swedish Transport and Communications Research Board, KFB, Vol. 5, Stockholm, Sweden, 1997 (in Swedish).

[49] Wall G., Exergy use in the Swedish society 1994, in: Cai R. et al. (Eds.), Proceedings of Thermodynamic Analysis and Improvement of Energy Systems, 10–13 June, Beijing World, China, 1997, pp. 403–413, <http://www.exergy.se/ftp/exse94.pdf>.

[50] Wall G., Exergy Conversion in the Japanese Society, Energy 15 (1990) 435–444, <http://www.exergy.se/ftp/japan85.pdf>.

[51] Wall G., Sciubba E., Naso V., Exergy use in the Italian society, Energy 19 (1994) 1267–1274.

[52] Ertesvag I.S., Mielnik M., Exergy analysis of the Norwegian society, Energy 25 (2000) 957–973.

[53] Ishida M., Zheng D., Graphic exergy analysis of chemical process systems by a graphic simulator, GSCHEMER, Comput. Chem. Engrg. 10 (1986) 525–532.

[54] Ayres R.U., Ayres L.W., Martinàs K., Eco-thermodynamics: Exergy and life cycle assessment, Working Paper, INSEAD, 96/04/EPS, Fontainebleau, 1996.

[55] Ayres R.U., Masini A., Waste exergy as a measure of potential harm, in: Ulgiati S. et al. (Eds.), Advances in Energy Studies—Energy Flows in Ecology and Economy, Muis, Italy, 1998, pp. 113–128.

[56] Wall G., Exergetics (1998), <http://www.exergy.se/ftp/exergetics.pdf>.

[57] Wall G., Exergy, ecology and democracy—concepts of a vital society, in: Szargut J. et al. (Eds.), Proceedings of International Conference on Energy Systems and Ecology 5–9 July, Krakow, Poland, 1993, pp. 111–121, <http://www.exergy.se/goran/eed/index.html>.

[58] Hirs G., Exergy Loss: A Basis for Energy Taxing, Univ. of Twente, The Netherlands, 1994, <http://www.thw.wb.utwente.nl/topics/exergy/publications/extax.htm>.